



SULPHUR PROCESSING SOLUTIONS



Experts in process engineering
and filtration solutions
What gets **measured**, gets **managed**



At Sulphurnet, we focus on delivering **tailored solutions** for sulphur melting and purification plants. Our process engineering and filtration skills enable us to provide a comprehensive design package, all in one place. We manage **every phase of your project**, from Basic Process Design to complete production units, including after-sales support.

Our instruments are optimally designed specifically for sulphur applications, ensuring **maximum efficiency and safety**.

If you need innovative solutions, our team is dedicated to exploring new possibilities, designing **custom-made solutions**, and achieving effective results. We aim to turn your challenges into successes.

Choose Sulphurnet for **expertise** and customized solutions that enhance efficiency and performance in your chemical processes.

Sulphurnet – Get it right the first time

Advanced Filtration Solutions

Services **1**

Sulphur Melting Equipment **2**

Sulphur Filtration Equipment **3**

Consumables **4**

Sulphur Melting and Filtration Modules **5**

Liquid Sulphur Pump Systems **6**

Instrumentation **7**

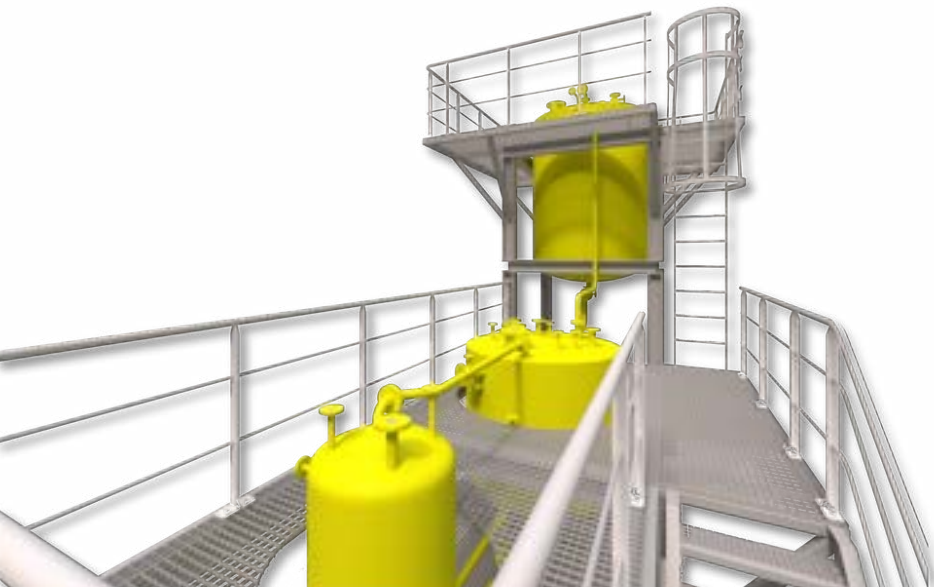

Services

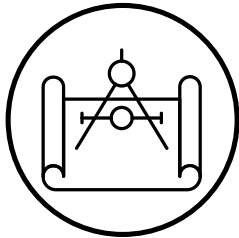

Engineering and Supply of Proprietary equipment

Basic Engineering
Detailed Engineering
Manufacturing and Procurement



Construction Support & Commissioning

Construction Phase Support
SOP Development
Start-up Protocols & Execution
Plant Operation Manuals
Operator Training



Plant Audits

Inspections
Maintenance Recommendations
Plant Optimization

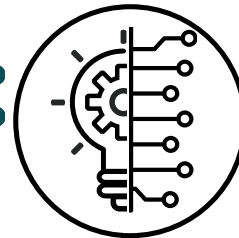

Sulphur Solutions

Sulphur Melting Tank
Liquid Sulphur Pressure Filter
Liquid Sulphur Polishing Filter
Self-Cleaning Liquid Sulphur Filter
Jacketed Valves
Instrumentation

We specialize in designing and producing advanced **liquid sulphur plants**, providing comprehensive sulphur melting and filtration solutions that meet the highest standards. Our plant designs cover every process part, from feeding solid sulphur to delivering clean sulphur to storage tanks.

We address the unique challenges of sulphur melting and purification, tackling corrosion, cold spots, dust collection, and firefighting. Our **optimized** sizing of **melters and filtration processes** enhances efficiency and prevents oversizing. We can handle process concepts up to 2500 MTPD within a single plant, expedite project completion and deliver a competitive edge.

Engineering Services

Sulphurnet's engineering team manages all aspects of industrial projects, offering guidance from project concept to helping clients adopt cutting-edge technologies and **optimizing CAPEX, OPEX, efficiency, and quality.**

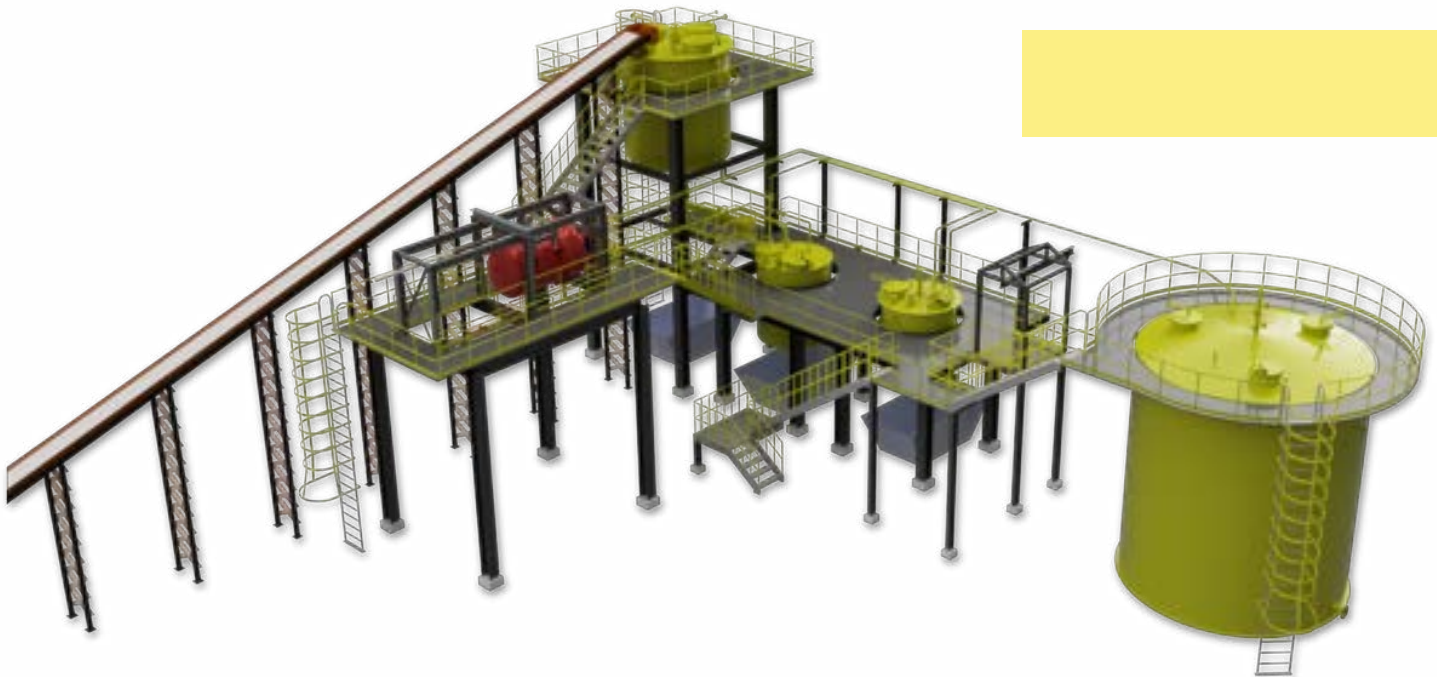

■ **Basic Engineering**

We establish project foundations by defining scope, developing preliminary designs, and providing initial investment estimates of main equipment (+/- 30%) and schedules. Deliverables include process calculations, P&IDs, equipment design, and datasheets.

■ **Detailed Engineering**

Our detailed engineering finalizes the design of equipment and structures, providing extensive documentation compliant with safety standards and client specifications. Safety is prioritized through all design and production stages with thorough HAZOP meetings.



Sulphur Melting Equipment

Above-Ground Sulphur Melter

Sulphurnet's above-ground melters are equipped with steam coils to efficiently melt solid sulphur. An agitator enhances the melting rate by increasing sulphur velocity along the heating coils, keeping solids in suspension, and improving lime neutralization. The dish-bottom tank allows for continuous operation without draining interruptions and is internally lined with bricks to prevent corrosion.

- Excellent heat transfer with efficient agitation
- Continuous operation with bottom draining
- Extended lifespan due to corrosion protection
- Low H_2S emissions
- Superior neutralization

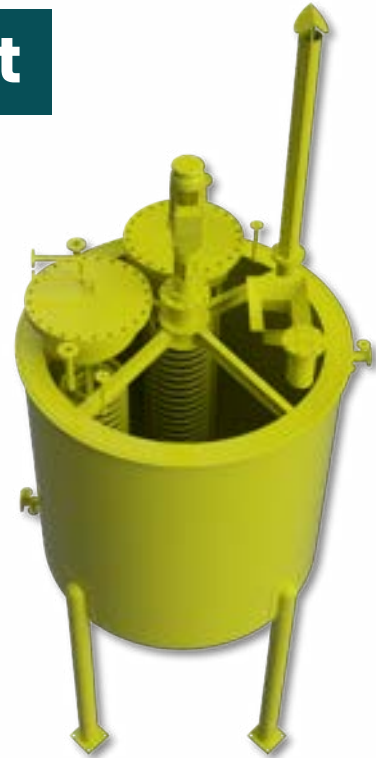

Flash Sulphur Melter

The Flash Sulphur Melter is designed to boost existing plant capacity and handle sulphur with high moisture content or powder form.

- Compact design with a small footprint
- Enhanced capacity for existing melting plants
- Low maintenance with no moving parts
- Less corrosion with no internal coils
- Effective for high moisture and powder sulphur
- Reduced foaming issues

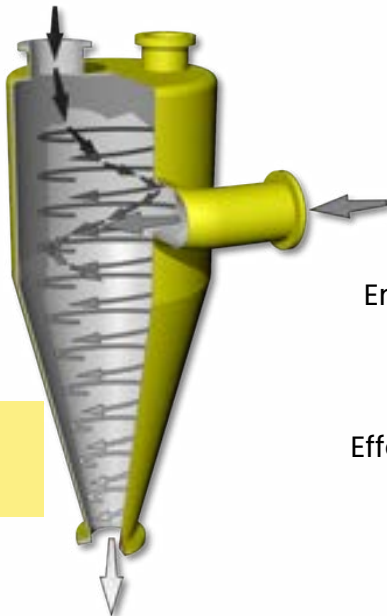

C-Melter

The C-Melter is a compact, container-sized system ideal for the sulphuric acid industry. Solid sulphur is introduced into the well-agitated melting chamber, where it contacts the internal heat exchanger. A submersed pump transfers the liquid sulphur to the filter, removing impurities to produce sulphur with an ash level of less than 10 ppm, ensuring long catalyst life.

- **Capacity:** 20–80 metric tons of sulphur per day
- **Internal Heat Exchanger:** Allows replacement without process interruption
- **Vigorous Agitation:** Intensifies the melting process
- **Dirty Sulphur Pumping Section:** Facilitates further processing
- **Corrosion Protection:** Extends equipment lifetime



WHAT
GETS **MEASURED**
GETS **MANAGED**



Sulphur Filtration Equipment

Liquid Sulphur Pressure Filter

The pressure leaf filter is a time-tested solution with over 70 years of proven reliability. Ideal for high flow rates and filtration areas above 120 m², it is also suitable for smaller applications. We've optimized this classic design to enhance performance and fit seamlessly into modern automated systems.

- **Automation Ready:** Simple to integrate into automated systems.
- **Easy Maintenance:** Fast, simple cleaning processes.
- **Clean Operation:** Prevents leaks, corrosion, and operational issues.
- **Stationary Filter Leaves:** Prevents cake dropping during opening.
- **Cake Discharge:** Suitable for both dry and wet cake discharge.
- **Quick Closure:** Features a durable gasket with a long lifespan.
- **Hydraulic Operation:** Provides consistent and reliable performance.
- **Customizable:** Designed to meet your specific needs.

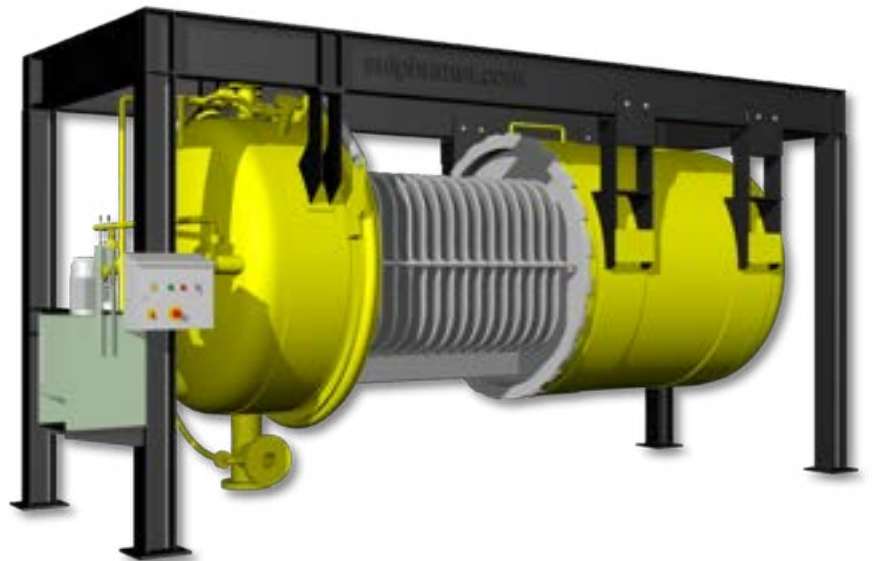



Self-Cleaning Liquid Sulphur Filter

It ensures optimal filtration by removing remaining contaminants, achieving filtration efficiency as low as 10 ppm.

- Automated cleaning, no operators required ■
- Efficient back-blowing cleaning process ■
- Reduces ash levels, extending catalyst bed lifespan ■
- Compact design suitable for existing plants ■
- Low investment and maintenance costs ■
- No moving parts, reducing maintenance needs ■

Liquid Sulphur Polishing Filter

This filter removes fine particles that pass through the primary pressure leaf filter. It efficiently eliminates fine solids like ashes and filter aids to levels below 8 ppm for particles larger than 5 microns.

- High-efficiency filtration, reducing ash levels to 8 ppm
- Efficient self-cleaning with steam back flushing
- Durable ceramic filter elements
- Compact design with a small footprint

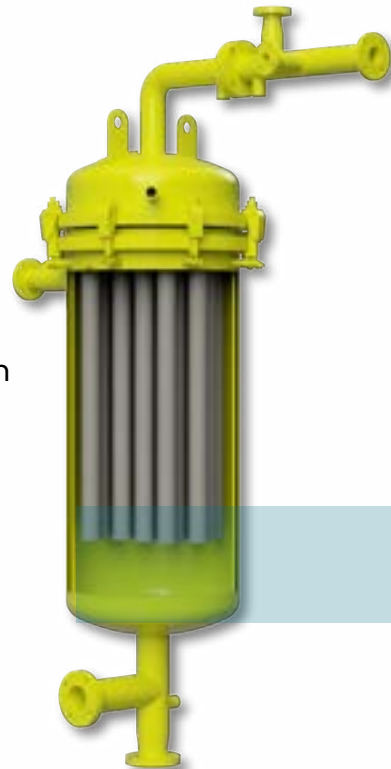

Consumables

Filter Leaves



Our Filter leaves are engineered to deliver exceptional performance, durability, and chemical compatibility across various applications. Our filter leaves feature a sophisticated multi-layer design, ensuring mechanical strength and minimal moisture retention in filter cakes.

Our standard design includes five layers, with the middle layers being thicker to facilitate unrestricted filtrate flow and enhance drainage and filtration.

Our Liquid Sulphur Polishing Filters primarily use ceramic filter tubes as the filtration medium. Made from aluminum oxide, these tubes are known for their exceptional chemical resistance and form a robust, uniform porous structure.

The fine porous varieties, with their smooth surfaces, are particularly well-suited for fine filtration, utilizing backwash cleaning technology. Solids are effectively retained on the exterior of the tubes, while the filter cake is efficiently removed by back blowing with steam.

Ceramic Filter Tubes





**Smart
investment.
Experienced
engineering.**

Sulphur Melting and Filtration Modules

We offer modular units for sulphur melting and filtration, adaptable for capacities from 5 to 300 metric tons of sulphur per day. These units can be combined to create a complete, compact sulphur melting and purification plant.

- **Plug and Play Solution:** Efficient, low CAPEX design for easy setup and operation.

- **High-Quality Sulphur:** Produces high-quality sulphur with minimal losses.

- **Fully Equipped:** Includes melting, precoat tank, filters, structural steel, piping, valves, pumps, instrumentation, and pre-coat equipment (on-site assembly required).

- **Efficient Operation:** The conveyor belt transports solid sulphur to the melting tank, where it is heated to form liquid sulphur, then flows to the dirty sulphur tank and is pumped to the liquid sulphur filter.

- **Elevated Melting Tank:** Allows for solids to be drained without stopping the unit, with an overflow system leading to the filtration module.

- **Filtration Module:** Achieves efficient retention and a solid concentration of 10 ppm, with elements connected for optimal process control.

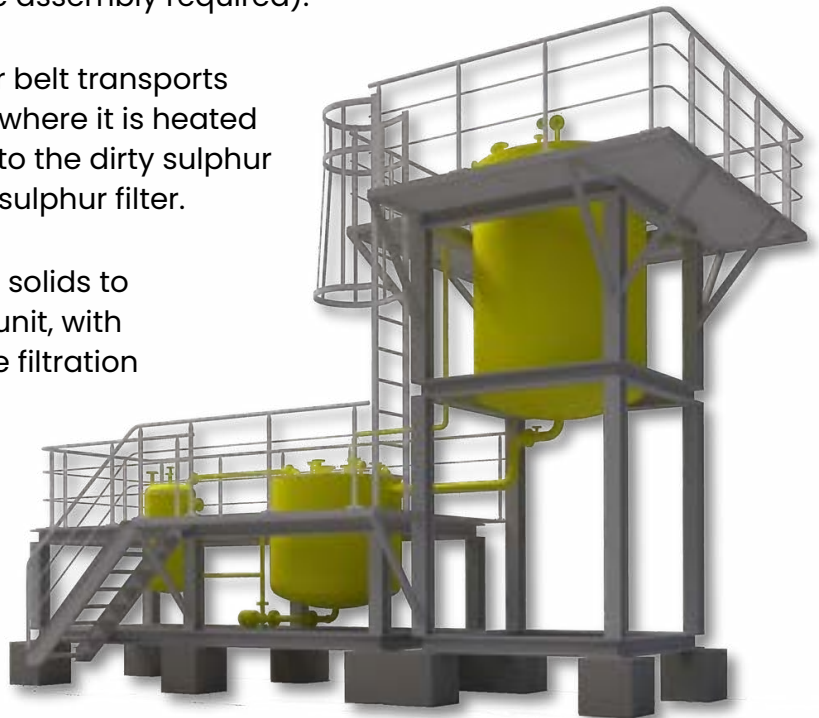

Modular Advantages:

Scalable:

Easily increase production with additional modules. ■

Flexible:

Optional improvements such as polishing filters, particle analyzers, and additional filtration units. ■

Customizable:

Adaptable to specific needs, including solid handling or liquid sulphur storage tanks. ■

Low OPEX:

Efficient design minimizes operational costs. ■

Transportable:

Easy to transport and install on-site. ■

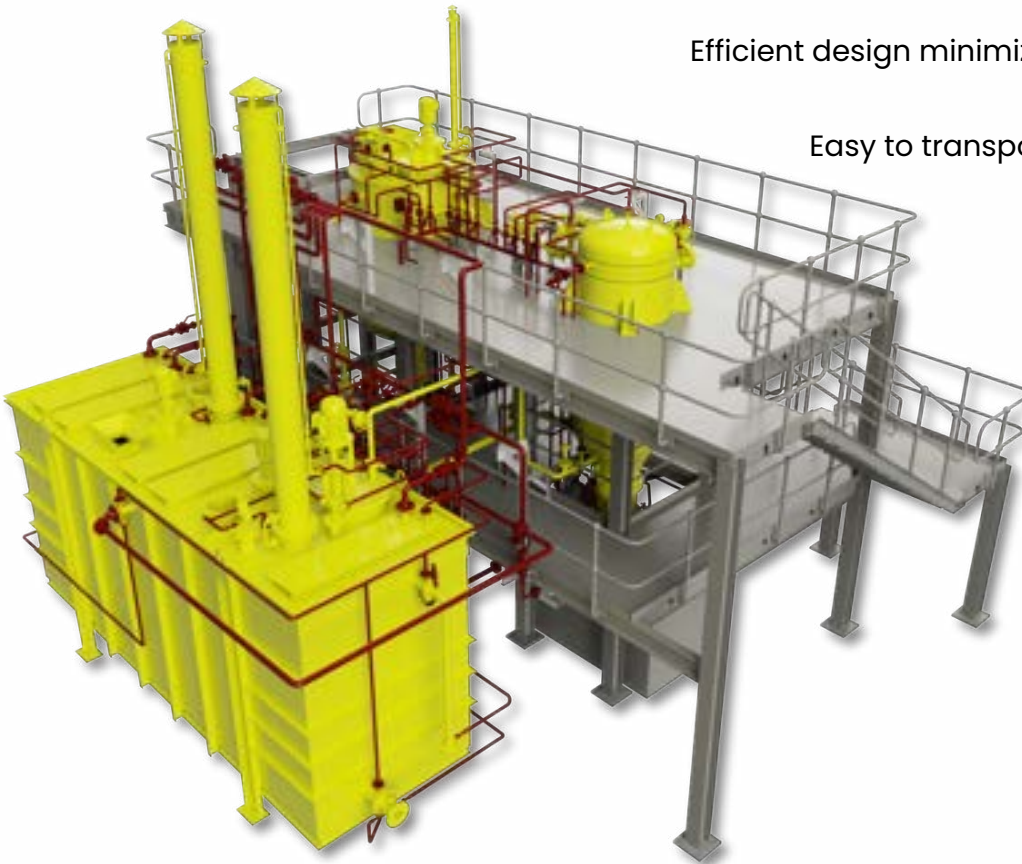

Liquid Sulphur Pump Systems

Sulphurnet provides advanced liquid sulphur pump skids for applications like truck/railcar loading and sulphur burner feeding. Each skid is built in a controlled environment, complete with jacketed piping, valves, and necessary instrumentation. Our systems meet local safety standards, with optional certifications such as ATEX, and can be integrated into existing DCS systems.

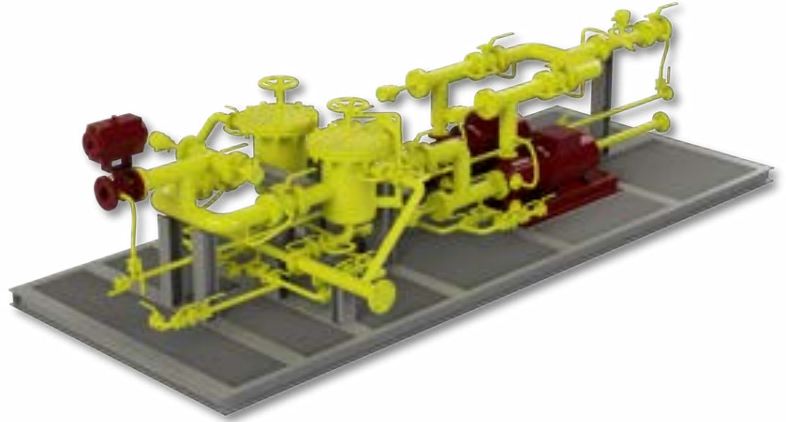

Key Benefits:

Truck Unloading Pump Skids

- Single point of contact for project support
- Quick installation with Plug and Play design
- High-quality construction in controlled conditions
- Specially selected pumps

Sulphur Burner Pump Skids

- Simplified project management
- Fast installation with minimal on-site labor
- Superior construction quality
- Custom pump configurations

IS IT
COMPLEX?
WE MAKE IT
SIMPLE.

Instrumentation

Turbidity Analyser



Our advanced monitoring system continuously measures ash concentration in liquid sulphur post-filtration. Real-time detection allows for immediate corrective actions, effectively minimizing the entry of ash into the clean side of the process.

Measures in low ppm range. The system is fitted with a jacketed measuring device and a control box with outputs to the control room.

Jacketed Radar Level Transmitter

Our unit ensures reliable and continuous level measurement of liquid sulphur, even with low-reflective mediums.

Equipped with a heating system on the antenna, it prevents sulphur condensation, maintaining accuracy and efficiency.



Pressure Indicator & Transmitter

Our pressure indicators and transmitters are specifically designed to offer versatility in form and connections to suit diverse applications, including differential pressure measurements.



Instrumentation

We offer a wide range of temperature sensors designed to cover various applications. The adaptable design allows for a large variety of customized thermometers to meet your specific needs.

Jacketed Valves for Liquid Sulphur



Sulphurnet offers a comprehensive range of valves with heating jackets, essential for maintaining a consistent process temperature to keep the media fluid. We offer both automated and manual operated valves to meet various operational needs.

Our ultrasonic flow meter offers excellent accuracy, robustness, and advanced transmitter functionality, making it ideal for liquid sulphur applications.

The sensor design ensures a smooth flow path, free from any obstructions that could disrupt the liquid flow. Ultrasonic flow measurement is unaffected by temperature, pressure, or viscosity.

Temperature Transmitter



Flowmeter





**Elevate Your
Process:
Superior Filtration
for Liquid Sulphur**

Instrumentation

Bubble Tube



The Bubble Tube Level Measurement System is a self-contained, low-cost instrument designed for precise level indication in liquid sulphur melting tanks. This system operates by measuring liquid level through density and pressure, making it ideal for challenging environments like a sulphur melting tank.

Proven Reliability:

Bubble tube systems have been trusted for decades. ■

Advanced Technology:

Combines simplistic operation with the latest electronic instruments. ■

Preferred Method:

Optimal for level measurement in sulphur melting tanks. ■



**More than 150 clients in
more than 45 countries.**

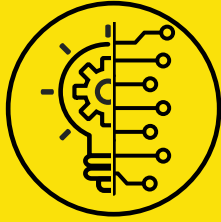

INNOVATION

We embrace new technologies to revolutionize filtration plants, ensuring our clients benefit from the latest advancements.



DEDICATION

We are committed to reducing production costs, improving quality, and enhancing safety and environmental performance for our clients worldwide.



EXPERIENCE

With over 50 years of combined experience in sulphur melting and filtration technology, we provide reliable solutions backed by a proven track record, ensuring excellence and trust in every project we undertake.

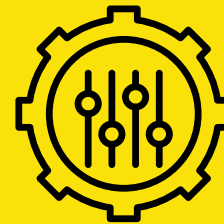

TAILOR MADE

We specialize in custom filtration systems tailored to each client's unique needs, ensuring optimal performance and seamless integration.

GET IN TOUCH TODAY

Sulphurnet offers an **all-in-one design package** that covers every stage of your project for sulphur processing plants, from the initial kick-off meeting to post-completion after-sales support.

We are dedicated to **more than just filtration systems**; our mission is to help customers worldwide **reduce** production costs, **enhance** product quality and yields, and **improve** Safety, Health, and Environmental performance.

Contact us:

 www.sulphurnet.com

 [Follow us on LinkedIn](#)

 info@sulphurnet.com

 +31 345 476 627

Pascalweg 5-14

 4104 BE Culemborg
The Netherlands



**GET IT RIGHT THE
FIRST TIME**



TK-001
Clean Sulphur Tank